



PASCAL[®] Laser Indirect Ophthalmoscope (LIO)

(532 nm or 577 nm)

(Single-Spot Version)

Operator Manual

European Authorized Representative
Obelis
Boulevard Général Wahis 53
1030 Brussels
Belgium
Phone: +32.2.732.59.54
Fax: +32.2.732.60.03
www.obelis.net

Iridex Corporation
1212 Terra Bella Avenue
Mountain View, CA 94043
USA
Office: +1. 650.940.4700
Fax: +1.650.962.0486
www.iridexretina.com

This manual is copyrighted with all rights reserved. Under the copyright laws, this manual may not be copied in whole or in part or reproduced in any other media without the express written permission of Iridex Corporation. Permitted copies must carry the same proprietary and copyright notices as were affixed to the original under the law. Copying includes translation into another language.

Please note that while every effort has been made to ensure that the data given in this document is accurate, the information, figures, illustrations, tables, specifications and schematics contained herein are subject to change without notice.

Iridex Corporation[®], the Iridex Corporation Logo[™], PASCAL[®], and PASCAL Synthesis[™] are trademarks or registered trademarks of Iridex Corporation.

Table of Contents

| | |
|--|----|
| Table of Contents | 3 |
| Introduction | 4 |
| Setting Up and Using the LIO | 5 |
| Adjusting the Headband | 6 |
| Adjusting the Interpupillary Distance | 7 |
| Obtaining a Fused Image | 7 |
| Adjusting the Mirror Angle | 7 |
| Turning on the Illumination | 7 |
| Setting the Aperture | 8 |
| Selecting the Filter | 9 |
| Adjusting the Illumination | 10 |
| Adjusting the Laser Angle | 10 |
| Adapting the Power Supply | 11 |
| Laser Treatment | 12 |
| Examining the Fundus | 12 |
| Battery Charger | 13 |
| Inserting/Replacing the Battery Pack | 13 |
| Charging the Battery Pack | 14 |
| Mounting the Wireless Charger | 16 |
| Replacing the LED | 17 |
| Cleaning | 17 |
| Specifications | 18 |
| Product Labels | 18 |
| Service | 19 |
| General Safety and Regulatory Information | 20 |
| Device Classification | 20 |
| Intended Use | 20 |
| Warnings and Cautions | 20 |
| Safety Considerations | 23 |
| Symbols | 24 |
| Electromagnetic Compatibility | 25 |
| Warranty Information | 33 |
| Warranty Shipments, Returns, and Adjustments | 33 |
| Decontamination of Returned Equipment | 34 |
| US Technical Service Information | 34 |
| WEEE Disposal | 34 |
| Decontamination Certification | 35 |

Introduction

Please read and follow these instructions carefully.

Iridex Corporation accepts full responsibility for safety, reliability and performance of the device only if:

- Service, readjustments, modifications and/or repairs are performed exclusively by Iridex Corporation-certified personnel.
- The electrical installation of the treatment room complies with the applicable IEC, CEC and NEC requirements.

The warranty is void if any of these warnings are disregarded.

Iridex Corporation reserves the right to make changes to the device(s) herein. Device(s), therefore, may not agree in detail with the published design or specifications. All specifications are subject to change without notice. Please contact Iridex Corporation or your local Iridex Corporation representative for information on changes and new products.

Setting Up and Using the LIO

The Iridex Corporation LIO is designed to connect to the PASCAL laser system. An optical system projects an aiming and treatment laser beam delivered from the laser via a fiber optic cable. The user can adjust the angle of projection of the laser by approximately $\pm 3^\circ$. The illumination patch is separately adjustable.



Connecting the LIO to the laser

1. Turn on the laser console, as described in the Pascal operator manual.
2. Remove the dust caps from the laser optical fiber connector and the optical fiber port on the front of the laser console.
3. Line up the pin in the fiber connector with the slot in the fiber port on PASCAL or Streamline.
4. Screw on the fiber connector collar until it stops. Do not over tighten the collar.

NOTE: Reinstall the dust caps after use.

Adjusting the Headband

Ophthalmoscope Angle Alignment

For vertical alignment of the eyepieces and binocular block, adjust the height of the metal outer brow bar, if necessary, by using the brow band tension knobs located on the sides of the headset (fig 3).

Position the binocular block as close to the eyes or spectacles as possible for maximum field of view. Slightly loosen the ophthalmoscope angle knob to allow for adjustment and tighten when in position (fig 4).

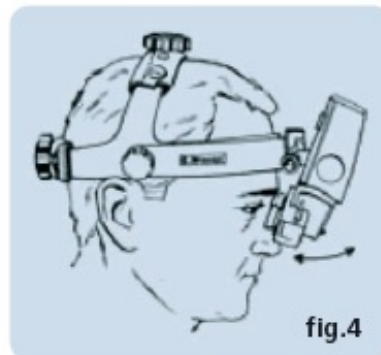
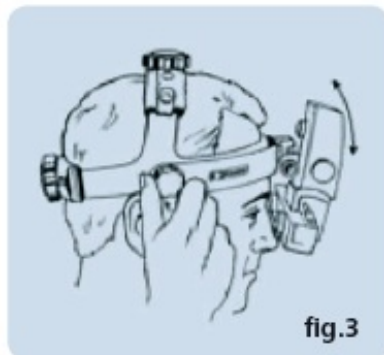
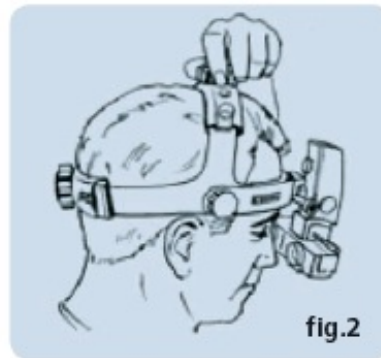

Adjusting the Interpupillary Distance

Because the eyes are dissociated, particular care must be taken to ensure the optics (eyepieces) are set properly in front of each eye.

Always set the aperture selection to the large light patch for this exercise.

Place an object (e.g., your thumb) approximately 40 cm from the face, and center it horizontally in the light patch. Then, close one eye. Using the thumb and forefinger of the opposite hand, slide the interpupillary distance control of the open eye (located directly under each eyepiece) so that your object moves into the center of the field, keeping the object in the center of the light patch. Repeat for the other eye.

Obtaining a Fused Image

Ensure that a singular fused image is obtained, as follows:

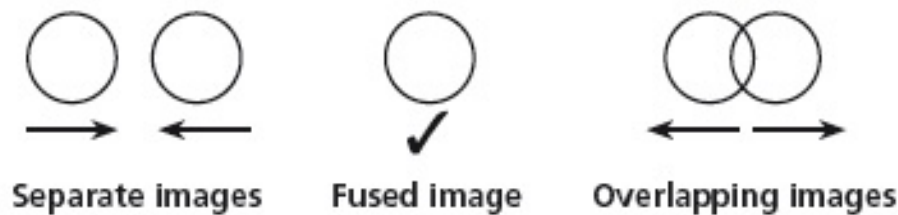

Adjusting the Mirror Angle

The light is positioned vertically into the upper two thirds of the field of view by rotating the mirror angle spindle located on either side of the binocular block.

Turning on the Illumination

Turn on the illumination by rotating the headband dimmer switch in a counter-clockwise direction.

Setting the Aperture

Rotate the aperture lever on the right side of the unit to select the aperture. The illumination and viewing mirrors automatically adjust for maximum stereopsis.

Large

The large, round, homogeneous patch is suitable for routine examinations through fully dilated pupils. The mirror remains in the forward position and the optics are diverged.

Intermediate

The intermediate patch is designed to reduce reflections when entering a partially or poorly dilated pupil (3mm). It is also ideal for closer inspection of particular fundal areas. The mirror and optics stay in the mid position.

Small

The small patch is ideal for small, undilated pupils. The mirror moves back and the optics automatically converge.

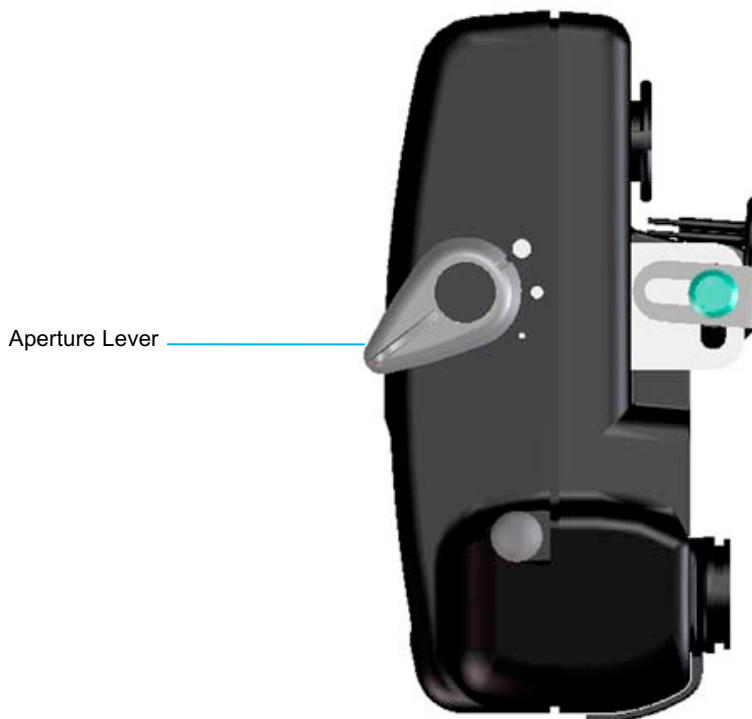

Selecting the Filter

Rotate the filter lever on the right side of the unit to select the filter.

Ensure filter is seated in proper position to prevent occlusion of vision.

Cobalt Blue

Used for fluorescein angiography

Clear (No Filter)

Ideal for inspecting a specific pathology, when brighter, whiter light is desired

Red-free

Reduces red light, so blood appears black, silhouetted against a dark background

Diffuser

Produces an extra wide beam of diffused light, which permits a more relaxed technique during challenging fundus examinations

NOTE

Beginners may find the diffuser filter helpful, because the alignment between the headset, the condensing lens, and the pupil, in order to achieve a full lens image, is not as critical as with a conventional beam.

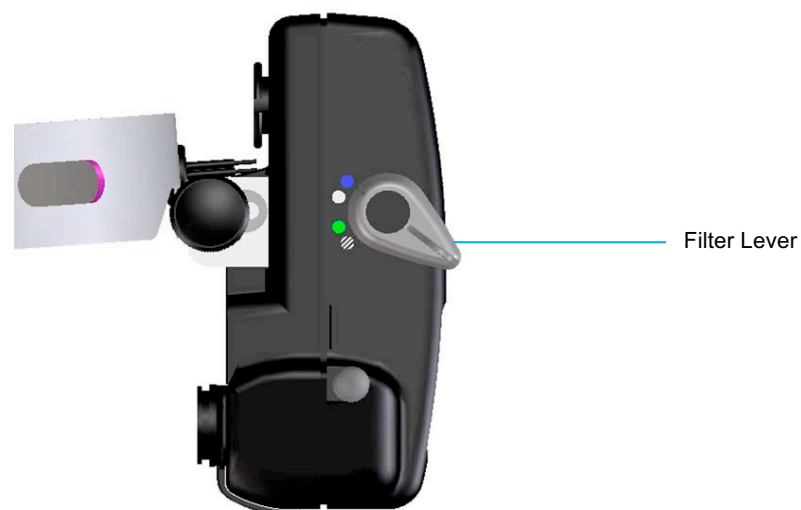

Adjusting the Illumination

Rotate the illumination adjustment control on the front of the unit to adjust the illumination patch. The illumination control has a larger adjustment range than the laser control, so it is best to adjust the laser first then overlay the illumination.

Adjusting the Laser Angle

Rotate the laser angle control on the front of the unit to adjust the angle of projection of the laser up or down by 3 degrees either side of the optical axis.



Adapting the Power Supply

Replace the blanking plate with the appropriate mains plug adapter, if required, or use IEC 60320 Type 7 connector (not supplied).

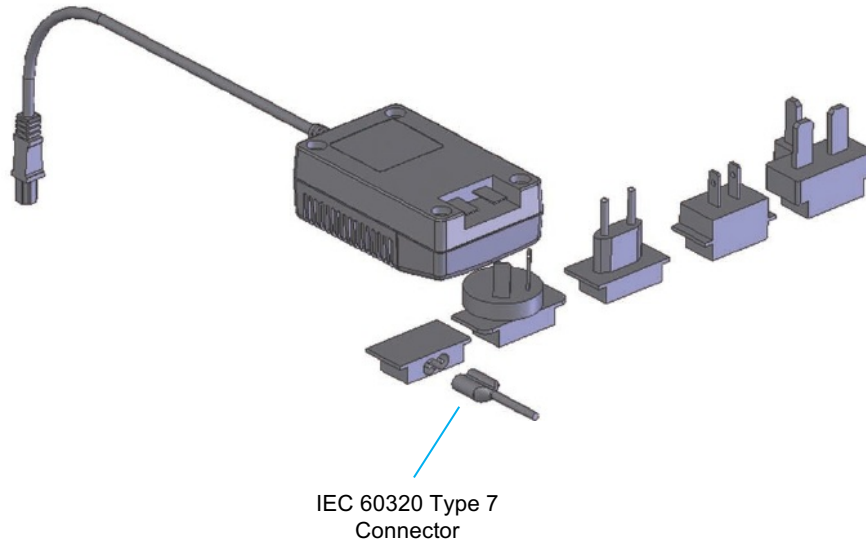

Laser Treatment

Examining the Fundus

1. Prepare the patient (e.g., dilate the pupils).
2. Set the illumination to a low intensity. Always start with a low intensity to protect the patient's eyes and increase lamp life.
3. Hold the aspheric lens in front of the patient's eye so that the engraving on the lens mount faces you. Let your little finger rest on the patient's head to support your hand. The distance between you and the patient should be about 40 cm.
4. Center the illumination beam in the patient's pupil. Bring the fundus image into focus by moving your head forward or backward and changing the position of the aspheric lens.

Before performing laser treatment you should be thoroughly familiar with the operation of the laser indirect ophthalmoscope as a diagnostic instrument and with the PASCAL laser system.

Perform the following procedure in conjunction with the instructions in the Pascal operator manual.

1. Prepare the patient for treatment.



Use care when treating thru cataracts, opaque vitreous fluid or when performing treatment with reduced or compromised viewing of target tissue

2. Select the desired treatment parameters, as described in the Pascal operator manual.
3. Make any necessary adjustments to the headset to ensure safe and clear view of the retina.
4. Select READY mode to turn on the aiming beam.
5. Position the aspheric lens, and observe the fundus of the patient's eye through the LIO. The aiming beam should be visible as a red spot in the center of the field of view. The aiming beam should appear as a round and uniform spot located in the center of the field of view. Do not continue with treatment if the aim beam spot is not round or if it appears distorted or clipped and does not have uniform brightness.



Never fire the laser if the aiming beam is not clearly visible on the target tissue

6. Move your head forward and backward until you obtain the smallest spot size. You may fail to achieve the desired physiological effect if the laser spot is not properly focused. If you are using the 20 D aspheric lens, the diameter of the spot will be 360 μm (for an emmetropic patient eye).
7. Depress the footswitch to deliver the treatment laser beam to the tissue.

Battery Charger

Inserting/Replacing the Battery Pack

1. Press the release button to release the battery pack.
2. Lift the battery pack from the cradle.
3. Place the new battery pack in the cradle until fully engaged.



Charging the Battery Pack

1. Replace the blanking plate on the power supply with the appropriate mains plug adapter.
2. Connect the power supply cable to the power input socket on the charger.
3. Plug the power supply into the mains outlet.
4. Place the spare battery pack or headset into the charger.

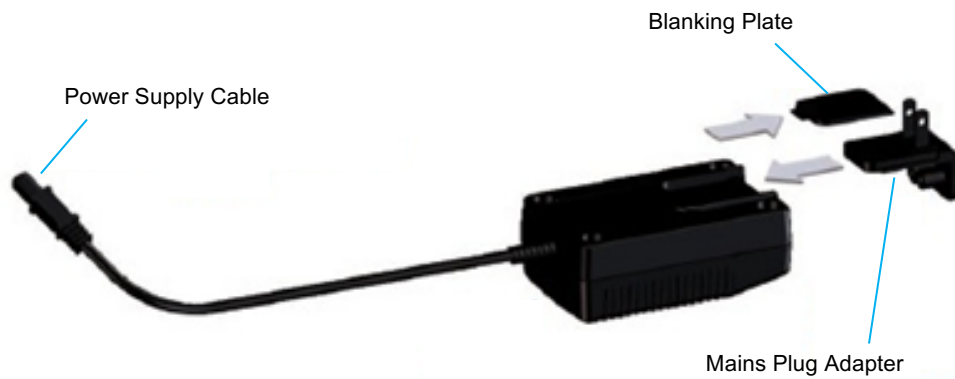

Indicator Lights

On headband battery holder:

- flashing LED—battery requires charging

On charger:

- no indicator—battery fully charged
- flashing indicator—top up charge
- solid indicator—rapid charge

The battery pack can be used at any time during the charging cycle and will automatically resume charging when placed back in the charger. The lights on the charger indicates which battery is being charged.

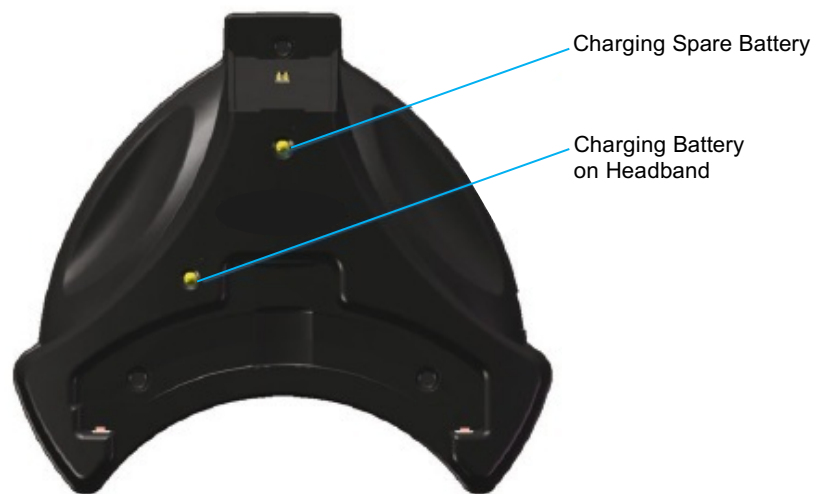

Charging Cycle

The battery on the headband takes 2 hours to fully charge and will last approximately 2 hours on full power. The spare battery takes 4 hours to charge.

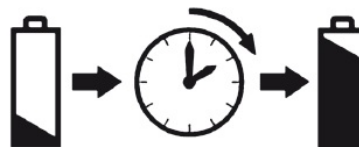

Mounting the Wireless Charger

Use the template document provided to mark the position of the charger and drill holes.

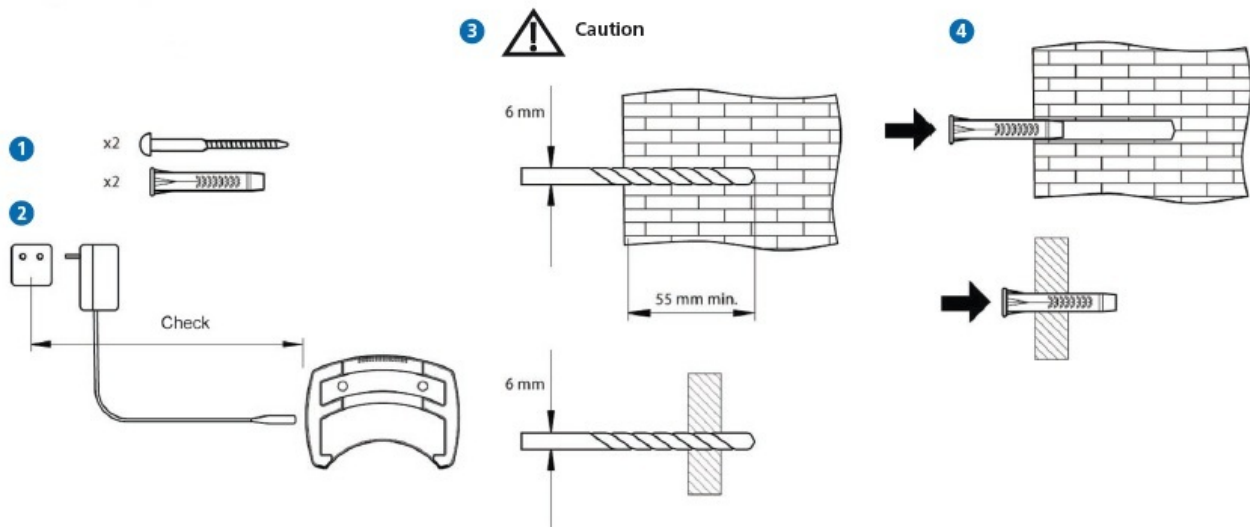
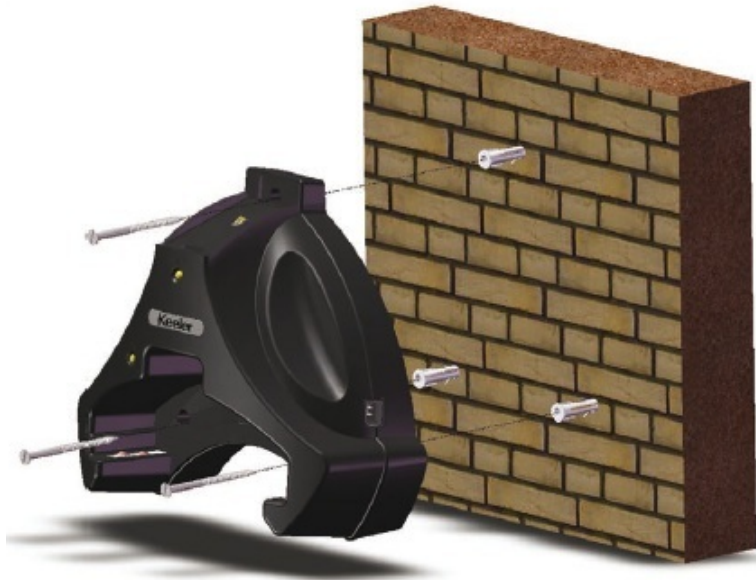

Replacing the LED



The LED may get hot during prolonged use. Allow it to cool before replacing.

1. Remove the LED from the back of the unit.
2. Insert the new LED, ensuring the alignment key is properly oriented and the LED is pushed all the way into the unit.

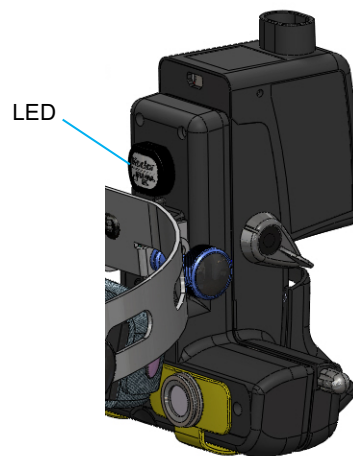

Cleaning

Use only manual, non-immersion cleaning as described. Do not autoclave or immerse in cleaning fluids.

1. Disconnect the power supply from the source.
2. Wipe the external surfaces with a clean, absorbent, non-shedding cloth dampened with a water/detergent solution (2% detergent by volume) or water/isopropyl alcohol solution (70% IPA by volume). Avoid optical surfaces.



Ensure the cloth is not saturated with solution and excess solution does not enter the instrument.

3. Carefully hand-dry all surfaces using a clean, non-shedding cloth.
4. Safely dispose of used cleaning materials.

| | |
|---|--|
| <div data-bbox="248 195 406 268" style="border: 2px solid green; padding: 2px; display: inline-block; margin-bottom: 10px;">532nm</div> <div data-bbox="248 300 406 373" style="border: 2px solid yellow; padding: 2px; display: inline-block;">577nm</div> | System Wavelength Compatibility |
| <div data-bbox="248 415 876 478" style="border: 1px solid black; padding: 5px; display: inline-block;"> SYSTEM SN: USE ONLY WITH LIO SN: </div> | When LIO is calibrated to a specific laser system. |

Service

There are no user serviceable parts. Please refer all service requests to your local Iridex Corporation representative.

General Safety and Regulatory Information

Iridex Corporation products are precision medical instruments that have undergone extensive testing. With proper handling, they are useful and reliable clinical instruments. To protect operating personnel and patients, this entire manual and the PASCAL laser system operator manual should be read thoroughly before operation.

Iridex Corporation does not recommend specific clinical practices. The following precautions are extensive but may not be complete.

Device Classification

CE Regulation 93/42 EEC: Class IIb

FDA: Class II

Intended Use

The LIO is intended for use by medical professionals trained in the use of ophthalmic laser equipment and procedures.

US Federal law restricts this device to sale by or on the order of a healthcare practitioner licensed by law of the State in which he/she practices to use or order use of the device for its indicated uses.

The LIO is intended for use in photocoagulating ocular tissue in the treatment of diseases of the eye.

Warnings and Cautions



The Laser Indirect Ophthalmoscope (LIO) is intended for the treatment of ocular pathology and is indicated for use in retinal photocoagulation procedures. The LIO is indicated for use for the particular indications of the PASCAL® laser system to which it is attached.

This device is designed for safe use with a laser of specific wavelength. Check the markings on the top of the LIO (near the optical fiber connection), and ensure they match those on the connected laser.

The LIO contains safety filters to reduce reflected laser light to safe levels for users. Always look through the ophthalmoscope when the treatment beam is activated. Do not look over the ophthalmoscope when the treatment beam is activated.

Test prior to use.

To minimize risk of patient movement during operation, ensure patient has been adequately prepared.

Minimize possible distractions before beginning treatment.

Ensure headband is secure to prevent movement during treatment.

Ensure fiber optic cable is routed carefully and has enough slack to prevent tugging or snagging during treatment.

All attending personnel must wear laser safety glasses matching the operating wavelength of the laser.

Ensure LIO is serviced as indicated on the device.

Check product for signs of transport / storage damage prior to use.

Do not use if product is visibly damaged, and periodically inspect for signs of damage.

Do not use in the presence of flammable gases / liquids, or in an oxygen rich environment.

Do not immerse product in fluids.

Do not dispose of battery in fire, puncture or short circuit.

Do not use a battery that is deformed, leaking, corroded or visually damaged. Handle a damaged or leaking battery with care. If you come into contact with electrolyte, wash exposed area with soap and water. If it contacts the eye, seek medical attention immediately.



Do not fit mains power adapter into a damaged mains outlet socket.



Route power cords safely to eliminate risk of tripping or damage to equipment.



LED's can reach high temperatures in use – allow to cool before handling.



Do not exceed maximum recommended exposure time.



After removing the LED, do not touch the LED contacts and the patient simultaneously.



Use only Iridex Corporation-approved parts and accessories, or device safety and performance may be compromised.

Use only Iridex Corporation-approved batteries, chargers and power supplies as per the accessories listed.

The product has been designed to function safely when at an ambient temperature between +10°C and +35°C.

Keep out of the reach of children.

To prevent condensation from forming, allow instrument to come to room temperature before use.

For indoor use only (protect from moisture).

When replacing lithium battery pack, turn off device and attach new pack.

Remove batteries when device may not be used for prolonged periods.

Do not charge battery in any environment where the temperature may exceed 40°C or fall below 0°C.

There are no user-serviceable parts inside. Contact authorized service representative for further information.

Ensure device is securely held in docking station to minimize risk of injury or damage to equipment.

Follow guidance on cleaning / routine maintenance to prevent personal injury / damage to equipment.

Dispose of batteries in line with local environmental regulations.



Switch off the electrical supply and disconnect from the mains electrical supply before cleaning and inspection.

Safety Considerations



















Eye exposure to intense light sources for extended periods of time poses a risk of retinal photic injury. The level of intensity of the light to use in any procedure must be made on a case by case basis, based on a risk-benefit judgment by the clinician. Use of insufficient intensity may result in inadequate visualization and in adverse effects more serious than retinal photic damage. Further, despite all efforts to minimize the risk of retinal damage, damage may still occur. Retinal photic injury is a possible complication of the need to use bright light to clearly visualize ocular structure during delicate ophthalmic surgical procedures.

While no visible retinal lesions have been identified for ophthalmic instruments, it is recommended that illumination levels be set to the minimum level necessary to perform the function. Young children and persons with diseased eyes may be at a higher risk. The risk may also be increased if the person being examined has had any exposure with the same instrument or any other ophthalmic instrument using an intense visible light source during the previous 24 hours. This will apply particularly if the eye has been exposed to retinal photography.

The light emitted from this instrument is potentially hazardous. The longer the duration of exposure, the greater the risk of ocular damage. Exposure to light from this instrument when operated at maximum intensity will exceed the safety guideline after 60 minutes.

Symbols

| | |
|---|--|
|  | Attention, refer to accompanying documentation |
|  | Tested to and conforms with 93/42/EEC Medical Device Directive |
|  | Double insulated |
|  | Manufacturer |
|  | WEEE symbol—contact your local representative for disposal information |
|  | Type B applied part |
|  | Mandatory action sign |
|  | Follow operating instructions |
|  | High voltage |
|  | Trip hazard |
|  | Optical radiation hazard |
|  | Hot surface |
|  | This way up |
|  | Keep dry |
|  | Fragile |
|  | Material suitable for recycling |

Electromagnetic Compatibility

Like other electrical medical devices, the LIO requires special precautions to ensure electromagnetic compatibility (EMC) with other electrical medical devices. To ensure EMC, the LIO must be installed and operated according to the EMC information provided in this manual.

Consult the tables below for guidance in placing the LIO.

| Guidance and manufacturer's declaration – electromagnetic emissions | | |
|---|-------------------|--|
| The PASCAL LIO is intended for use in the electromagnetic environment specified below. The customer or the user of the PASCAL LIO should assure that it is used in such an environment. | | |
| Emissions test | Compliance | Electromagnetic environment – guidance |
| RF emissions CISPR 11 | Group 1 | The PASCAL LIO uses RF energy only for its internal function. Therefore, its RF emissions are very low and are not likely to cause any interference in nearby electronic equipment. |
| RF emissions CISPR 11 | Class A | The PASCAL LIO is suitable for use in all establishments other than domestic establishments and those directly connected to the public low-voltage power supply network that supplies buildings used for domestic purposes |
| Harmonic emissions IEC 61000-3-2 | Not Applicable | |
| Voltage fluctuations/flicker emissions IEC 61000-3-3 | Not Applicable | |

| Guidance and manufacturer's declaration – electromagnetic immunity | | | |
|---|---|----------------------------|--|
| The PASCAL LIO is intended for use in the electromagnetic environment specified below. The customer or the user of the PASCAL LIO should assure that it is used in such an environment. | | | |
| Immunity test | IEC 60601 test level | Compliance level | Electromagnetic environment – guidance |
| Electrostatic discharge (ESD) IEC 61000-4-2 | ±6 kV contact ±8 kV air | ±6 kV contact ±8 kV air | Floors should be wood, concrete or ceramic tile. If floors are covered with synthetic material, the relative humidity should be at least 30 %. |
| Electrical fast transient/burst IEC 61000-4-4 | ±2 kV for power supply lines ±1 kV for input/output lines | Not Applicable | |
| Surge IEC 61000-4-5 | ±1 kV line(s) to line(s) ±2 kV line(s) to earth | Not Applicable | |
| Voltage dips, short interruptions and voltage variations on power supply input lines IEC 61000-4-11 | <5 % U_T (>95 % dip in U_T) for 0,5 cycle 40 % U_T (60 % dip in U_T) for 5 cycles 70 % U_T (30 % dip in U_T) for 25 cycles <5 % U_T (>95 % dip in U_T) for 5 s | Not Applicable | |
| Power frequency (50/60 Hz) magnetic field IEC 61000-4-8 | 3 A/m | 3 A/m | Power frequency magnetic fields should be at levels characteristic of a typical location in a typical commercial or hospital environment. |
| NOTE U_T is the a.c. mains voltage prior to application of the test level. | | | |

| Guidance and manufacturer's declaration – electromagnetic immunity | | | |
|---|-----------------------------|-------------------------|--|
| The PASCAL LIO is intended for use in the electromagnetic environment specified below. The customer or the user of the PASCAL LIO should assure that it is used in such an environment. | | | |
| Immunity test | IEC 60601 test level | Compliance level | Electromagnetic environment – guidance |
| Conducted RF IEC 61000-4-6 | 3 Vrms 150 kHz to 80 MHz | Not Applicable | Portable and mobile RF communications equipment should be used no closer to any part of the PASCAL LIO, including cables, than the recommended separation distance calculated from the equation applicable to the frequency of the transmitter. Recommended separation distance Not Applicable |
| Radiated RF IEC 61000-4-3 | 3 V/m 80 MHz to 2,5 GHz | 3 V/m | $d = 1,2 \sqrt{P}$ 80 MHz to 800 MHz $d = 2,3 \sqrt{P}$ 800 MHz to 2,5 GHz where P is the maximum output power rating of the transmitter in watts (W) according to the transmitter manufacturer and d is the recommended separation distance in metres (m). Field strengths from fixed RF transmitters, as determined by an electromagnetic site survey, ^a should be less than the compliance level in each frequency range. ^b Interference may occur in the vicinity of equipment marked with the following symbol:  |
| NOTE 1 At 80 MHz and 800 MHz, the higher frequency range applies. NOTE 2 These guidelines may not apply in all situations. Electromagnetic propagation is affected by absorption and reflection from structures, objects and people. | | | |
| ^a Field strengths from fixed transmitters, such as base stations for radio (cellular/cordless) telephones and land mobile radios, amateur radio, AM and FM radio broadcast and TV broadcast cannot be predicted theoretically with accuracy. To assess the electromagnetic environment due to fixed RF transmitters, an electromagnetic site survey should be considered. If the measured field strength in the location in which the PASCAL LIO is used exceeds the applicable RF compliance level above, the PASCAL LIO should be observed to verify normal operation. If abnormal performance is observed, additional measures may be necessary, such as re-orienting or relocating the PASCAL LIO. | | | |
| ^b Over the frequency range 150 kHz to 80 MHz, the compliance level is not applicable. | | | |

Recommended separation distances between portable and mobile RF communications equipment and the PASCAL LIO

The PASCAL LIO is intended for use in an electromagnetic environment in which radiated RF disturbances are controlled. The customer or the user of the PASCAL LIO can help prevent electromagnetic interference by maintaining a minimum distance between portable and mobile RF communications equipment (transmitters) and the PASCAL LIO as recommended below, according to the maximum output power of the communications equipment.

| Rated maximum output power of transmitter W | Separation distance according to frequency of transmitter m | | |
|--|--|--|---|
| | 150 kHz to 80 MHz <i>Not applicable</i> | 80 MHz to 800 MHz $d = 1.17 \sqrt{P}$ | 800 MHz to 2,5 GHz $d = 2.33 \sqrt{P}$ |
| 0.01 | Not applicable | 0.12 | 0.23 |
| 0.1 | Not applicable | 0.37 | 0.74 |
| 1 | Not applicable | 1.17 | 2.33 |
| 10 | Not applicable | 3.69 | 7.38 |
| 100 | Not applicable | 11.67 | 23.33 |

For transmitters rated at a maximum output power not listed above, the recommended separation distance d in metres (m) can be estimated using the equation applicable to the frequency of the transmitter, where P is the maximum output power rating of the transmitter in watts (W) according to the transmitter manufacturer.

NOTE 1 At 80 MHz and 800 MHz, the separation distance for the higher frequency range applies.

NOTE 2 These guidelines may not apply in all situations. Electromagnetic propagation is affected by absorption and reflection from structures, objects and people.

This product conforms to the EMC standard (IEC 60601-1-2:2014). The expected electromagnetic environment for the whole life cycle is professional healthcare facility environment.

- a) MEDICAL ELECTRICAL EQUIPMENT needs special precautions regarding EMC and needs to be installed and put into service according to the EMC information provided in the ACCOMPANYING DOCUMENTS.
- b) Portable and mobile RF communications equipment can affect MEDICAL ELECTRICAL EQUIPMENT.
- c) The EQUIPMENT or SYSTEM should not be used adjacent to or stacked with other equipment. If adjacent or stacked use is necessary, the EQUIPMENT or SYSTEM should be observed to verify normal operation in the configuration in which it will be used.
- d) The use of the ACCESSORY, transducer or cable with EQUIPMENT and SYSTEMS other than those specified may result in increased EMISSION or decreased IMMUNITY of this EQUIPMENT and result in improper operation.
- e) Do not use the devices generating electromagnetic waves within 30cm from all the parts of the instrument and system. Those devices may have influence on this product.

| Item | Cable Shielded | Ferrite Core | Length (m) |
|--|----------------|--------------|------------|
| ACCESSORIES | | | |
| HEAD UP DISPLAY SYSTEM HUD-1 Module | - | - | - |
| PASCAL Laser Indirect Ophthalmoscope (LIO) | - | - | - |
| CABLES | | | |
| AC power cord (for SLIT LAMP) | Not Used | Not Used | 1.8 |
| AC power cord (for LASER CONSOLE) | Not Used | Not Used | 3.6 |
| SIP/SOP Cable (for SLA) | Used | Not Used | 1.9 |
| USB Cable (Unterminated) | Used | Not Used | N/A |
| USB Cable (for 3D Mouse) | Used | Not Used | 1.9 |
| USB Cable (for Monitor) | Used | Not Used | 1.9 |
| VGA Cable (for Monitor) | Not Used | Not Used | 1.9 |
| SIP/SOP Cable (for Footswitch) | Not Used | Not Used | 2.9 |
| SIP/SOP Cable (for LIO) | Not Used | Not Used | 1.9 |
| USB Cable (for HUD-1) | Not Used | Not Used | 1.8 |
| HDMI Cable (for HUD-1) | Not Used | Not Used | 1.8 |

Guidance and manufacturer's declaration - electromagnetic emissions

The PASCAL Synthesis Ophthalmic Scanning Laser System is intended for use in the electromagnetic environment specified below. The customer or the user of the PASCAL Synthesis Ophthalmic Scanning Laser System should assure that it is used in such an environment.

| Emissions test | Compliance | Electromagnetic environment - guidance |
|--|------------|--|
| RF emissions CISPR 11 | Group 1 | The PASCAL Synthesis Ophthalmic Scanning Laser System uses RF energy only for its internal function. Therefore, its RF emissions are very low and are not likely to cause any interference in nearby electronic equipment. |
| RF emissions CISPR 11 | Class B | The PASCAL Synthesis Ophthalmic Scanning Laser System is suitable for use in all establishments including domestic and those directly connected to the public low-voltage power supply network that supplies buildings used for domestic purposes. |
| Harmonic emissions IEC61000-3-2 | Class A | |
| Voltage fluctuations/ flicker emissions IEC61000-3-3 | Complies | |

Guidance and manufacturer's declaration - electromagnetic immunity

The PASCAL Synthesis Ophthalmic Scanning Laser System is intended for use in the electromagnetic environment specified below. The customer or the user of the PASCAL Synthesis Ophthalmic Scanning Laser System should assure that it is used in such an environment.

| Immunity test | IEC 60601 test level | Compliance level | Electromagnetic environment - guidance |
|--|--|--|--|
| Electrostatic discharge (ESD) IEC 61000-4-2 | ± 8 kV contact ± 15 kV air | ± 8 kV contact ± 15 kV air | Floors should be wood, concrete or ceramic tile. If floors are covered with synthetic material, the relative humidity should be at least 30%. |
| Electrical fast transient/burst IEC 61000-4-4 | ± 2 kV for power supply lines ± 1 kV for input/output lines Repetition frequency 100kHz | ± 2 kV for power supply lines ± 1 kV for input/output lines Repetition frequency 100kHz | Main power quality should be that of a typical commercial or hospital environment. |
| Surge IEC 61000-4-5 | ± 1 kV line(s) to line(s) ± 2 kV line(s) to earth | ± 1 kV line(s) to line(s) ± 2 kV line(s) to earth | Main power quality should be that of a typical commercial or hospital environment. |
| Voltage dips, short interruptions and Voltage variations on power supply input lines IEC 61000-4-11 | <5% U_t (>95% dip in U_t) for 0.5 cycle (with phase angle 0°, 45°, 90°, 135°, 180°, 225°, 270° and 315°) <5% U_t (>95% dip in U_t) for 1 cycle 70% U_t (30% dip in U_t) for 25/30 cycles <5% U_t (>95% dip in U_t) for 5 sec | <5% U_t (>95% dip in U_t) for 0.5 cycle (with phase angle 0°, 45°, 90°, 135°, 180°, 225°, 270° and 315°) <5% U_t (>95% dip in U_t) for 1 cycle 70% U_t (30% dip in U_t) for 25/30 cycles <5% U_t (>95% dip in U_t) for 5 sec | Main power quality should be that of a typical commercial or hospital environment. If the user or the PASCAL Synthesis Ophthalmic Scanning Laser System requires continued operation during main power interruptions, it is recommended that the PASCAL Synthesis Ophthalmic Scanning Laser System is powered from an uninterruptible power supply or battery. |
| Power frequency (50/60 Hz) magnetic field IEC 61000-4-8 | 30 A/m | 30 A/m | Power frequency magnetic fields should be at levels characteristic of a typical location in a typical commercial or hospital environment. |

NOTE U_t is the a.c. main voltage prior to application of the test level.

Guidance and manufacturer's declaration - electromagnetic immunity

The PASCAL Synthesis Ophthalmic Scanning Laser System is intended for use in the electromagnetic environment specified below. The customer or the user of the PASCAL Synthesis Ophthalmic Scanning Laser System should assure that it is used in such an environment.

| Immunity test | IEC 60601-1-2:2014 test level | Compliance level | Electromagnetic environment - guidance |
|--|--|--|--|
| <p>Conducted RF IEC 61000-4-6</p> <p>Radiated RF IEC 61000-4-3</p> | <p>3 Vrms 150kHz to 80MHz</p> <p>10 V/m 80MHz to 2.7GHz</p> <p>Proximity electromagnetic field from radio communication equipment a)</p> | <p>3 Vrms 150kHz to 80MHz</p> <p>10 V/m 80MHz to 2.7GHz</p> <p>Proximity electromagnetic field from radio communication equipment a)</p> | <p>Portable and mobile RF communications equipment should be used no closer to any part of the PASCAL Synthesis Ophthalmic Scanning Laser System, including cables, than the recommended separation distance calculated from the equation applicable to the frequency of the transmitter.</p> <p>Recommended separation distance</p> $d = \frac{6}{E} \sqrt{P}$ <p>where P is the maximum output power rating of the transmitter in watts (W) according to the transmitter manufacturer, d is the recommended separation distance in meters (m), and E is the radiation electromagnetic field level in volt/meter (V/m).</p> |
| NOTE 1 | These guidelines may not apply in all situations. Electromagnetic propagation is affected by absorption and reflection from structures, objects and people. | | |

a The table below shows the proximity electromagnetic field from radio communication equipment.

| Test frequency [MHz] | Band [MHz] | Equipment | Modulation | Maximum output[W] | Distance [m] | Immunity test value [V/m] |
|----------------------|------------|--|---------------------------|-------------------|--------------|---------------------------|
| 385 | 380-390 | TETRA 400 | Pulse modulation 18Hz | 1.8 | 0.3 | 27 |
| 450 | 430-470 | GMRS 460 FRS 460 | FM +/-5kHz 1kHz sine | 2 | 0.3 | 28 |
| 710 | 704-787 | LTE Band 13, 17 | Pulse modulation 217Hz | 0.2 | 0.3 | 9 |
| 745 | | | | | | |
| 780 | | | | | | |
| 810 | 800-960 | GSM 800/900 TETRA 800 iDEN820 CDMA850 LTE Band 5 | Pulse modulation 18Hz | 2 | 0.3 | 28 |
| 870 | | | | | | |
| 930 | | | | | | |
| 1720 | 1700-1990 | GSM 1800 CDMA 1900 GSM 1900 DECT LTE Band 1,3,4,25 UMTS | Pulse modulation 217Hz | 2 | 0.3 | 28 |
| 1845 | | | | | | |
| 1970 | | | | | | |
| 2450 | 2400-2570 | Bluetooth WLAN 802.11 b/g/n RFID 2450 LTE Band7 | Pulse modulation 217Hz | 2 | 0.3 | 28 |
| 5240 | 5100-5800 | WLAN 802.11 a/n | Pulse modulation 217Hz | 0.2 | 0.3 | 9 |
| 5500 | | | | | | |
| 5785 | | | | | | |



Warranty Information

Iridex Corporation warrants its products to be free from defects in material and workmanship at the original purchaser's location for 12 months.

In order to comply with this warranty, all internal adjustments or modifications must be made by Iridex Corporation-certified personnel or with the express permission of the Iridex Corporation Service Department. The warranty does not apply in the event of misuse, negligence or accidental damage.

The liability of Iridex Corporation under valid warranty claims is limited to repair or replacement at Iridex Corporation's plant or purchaser's place of business (or, if not practicable, a refund of the purchase price, all at the option of Iridex Corporation).

There are certain other limitations that apply to Iridex Corporation's warranty. Reference should be made to the terms and conditions of sale attached to Iridex Corporation's purchase agreement.

Warranty Shipments, Returns, and Adjustments

A warranty claim must be made promptly and must be received during the applicable warranty period by Iridex Corporation. If it becomes necessary to return a product for repair and/or adjustments, authorization from Iridex Corporation must be obtained. Instructions as to how and where products should be shipped will be provided by Iridex Corporation. Any product or component returned for examination and/or warranty repair shall be sent insured and prepaid via the means of transportation specified by Iridex Corporation. Shipping charges for all products or components replaced or repaired under warranty shall be the sole responsibility of the purchaser. In all cases, Iridex Corporation has sole responsibility for determining the cause and nature of failure and Iridex Corporation's determination with regard thereto will be final.

The foregoing Warranty is exclusive and in lieu of all other warranties, whether written, oral or implied, and shall be the purchaser's sole remedy and Iridex Corporation's sole liability on contract or warranty or otherwise for the product. Iridex Corporation disclaims any implied warranty or merchantability or fitness for a particular purpose. In no event shall Iridex Corporation be liable for any incidental or consequential damages arising out of or in connection with the use or performance of the goods delivered hereunder. The essential purpose of this provision is to limit Iridex Corporation's potential liability arising out of this sale.

Decontamination of Returned Equipment

To comply with United States postal and transportation law, equipment shipped to Iridex Corporation for repair or return must be properly decontaminated with a chemical germicide that is commercially available and cleared for sale as a Hospital Disinfectant. To ensure that all equipment has been properly decontaminated, a signed Decontamination Certificate (provided in this section) must be enclosed in the package.

If equipment is received without a Decontamination Certificate, Iridex Corporation will assume the product is contaminated and will assess the customer with decontamination costs.

Any inquiries should be directed to the Iridex Corporation Service Department. These include service of a device, assistance with troubleshooting the device and ordering accessories.

US Technical Service Information

Iridex Corporation
1212 Terra Bella Avenue
Mountain View, California 94043
USA

Phone: +1.650.940.4700
Fax :+1.650.962.0486
PASCALService@iridex.com

WEEE Disposal



WEEE ANNEX IV Symbol

Contact your local representative for disposal information.

Decontamination Certification

Under the provisions of Postal Law, Title 18, United States Code, Section 1716 and Department of Transportation regulations contained in CFR 49, Part 173.386 and 173.387, “etiologic agents, diagnostic specimens and biological products...are nonmailable...”

The undersigned therefore certifies that the Iridex Corporation equipment being returned herein by

Individual/Institution

City, State/Province, Country

Has undergone decontamination with a commercially available germicide cleared for use as a Hospital Disinfectant and is clean and free from biohazards, including – but not limited – human or animal blood, tissue **or** tissue fluids **or** components thereof.

The undersigned also agrees to reimburse Iridex Corporation for any costs incurred in decontaminating the enclosed equipment, in the event said item is received by Iridex Corporation in a contaminated condition.

Model: Laser Indirect Ophthalmoscope (LIO)

Serial Number: _____

Iridex Corporation

RMA Number: _____

Position/Title: _____

Name (Printed): _____

Signature

Date (DD/MM/YYYY)